

Exercise set 4 - Kinematics

Reminders

Simplified notation of sines and cosines

To simplify the notation, we use:

- $\sin(\theta_1) = s_1$
- $\cos(\theta_1) = c_1$
- $1 - \cos(\theta_1) = v_1$
- $\sin(\theta_2) = s_2$
- $\cos(\theta_2) = c_2$
- $1 - \cos(\theta_2) = v_2$
- $\cos(\theta_1 + \theta_2) = c_{1+2}$
- $\sin(\theta_1 + \theta_2) = s_{1+2}$
- $L_1 + L_2 = L_{1+2}$

Exercise 1

In this exercise you will work on the geometric model of the SCARA robot. Here we won't consider the rotation of the end effector. The output point will be the point P at the extremity of the second segment L_2 (see figure).

Give the direct geometric model (DGM) that expresses the coordinates (x, y) of point P as a function of the joint coordinates q_1 and q_2 .

Hint: use the homogeneous matrices of the following transformations:

1. Rotation of q_2 around P_{10} with coordinates $(L_1, 0)$
2. Rotation of q_1 around the origin

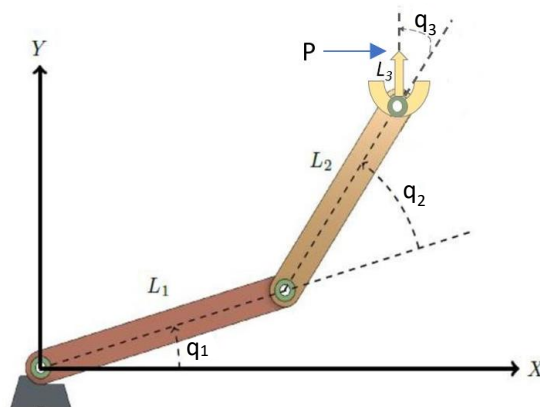

Exercise 2

In this exercise we take the output point as the tip of the end effector, as shown in the figures below. Therefore, here we consider the rotation of the end effector given by q_3 . In addition, as illustrated in the right figure below, we consider the possible translation along z given by q_4 .

The reference position of the end effector is $P(\theta_i = 0) = \begin{pmatrix} x_0 \\ 0 \\ z_0 \end{pmatrix} = \begin{pmatrix} L_{1+2+3} \\ 0 \\ z_0 \end{pmatrix}$. Give the position $P(q_i)$ as a function of the variables q_i .

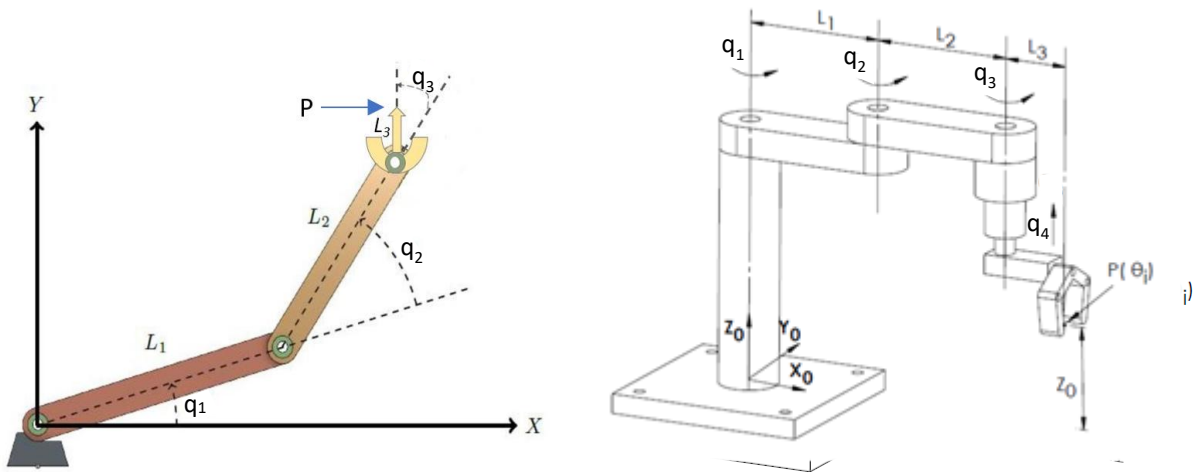

Exercise 3

The homogeneous matrices K_5 and K_6 of the DGM of the PUMA robot arm are given in the lecture slides. Give the missing matrices K_i , for $i = 1, 2, 3, 4$.

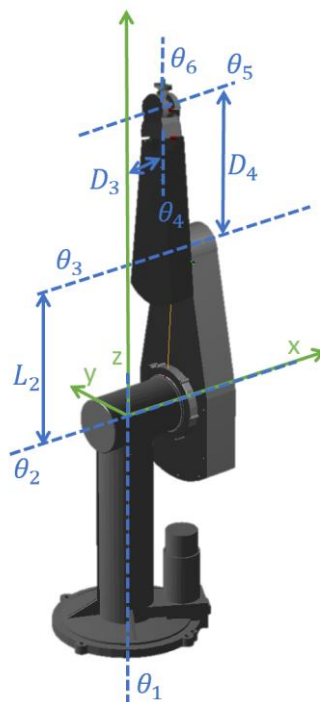

Exercise 4

Find the IGM (Inverse geometric model) of a 2 DOF planar robot (see figure below): given x and y , what are θ_1 and θ_2 ?

$$x = L_1 c_1 + L_2 c_{1+2}$$

$$y = L_1 s_1 + L_2 s_{1+2}$$

Hint: use the trigonometric formulas for the sine and cosine of the sum of two angles, as well as the one of the sum of squares of sine and cosine.

